

6. 前后悬架/Suspension

序号/ No.	名称 / Designation		页码 /Page No.
6,01	HOWO前悬架 (8X4, 11X17, 轴距1950, V7G转向) /Front Suspension		1
6,02	前桥横向稳定器 (1000车架, 880板簧距) /Front Stabilizer		4
6,03	HOWO 8×4前减震器/Front Shock Absorber		5
6,04	A7后悬架 (850、8+8、300高车架、铸造桥、铸造横梁)/Rear Suspension		7
6,05	搅拌车后横向稳定器 (850车架, 标准孔) /Stabilizer		13

6.01 HOWO前悬架 (8X4, 11X17, 轴距1950, V7G转向) /Front Suspension

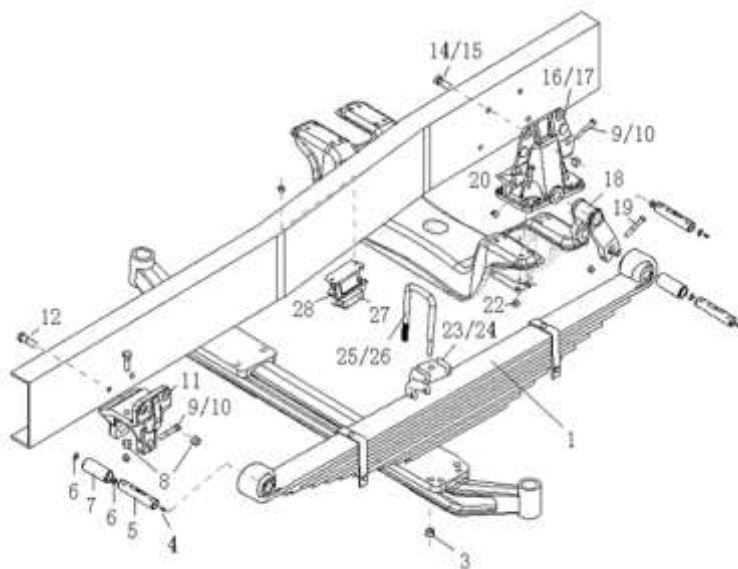

6.01 HOWO前悬架 (8X4, 11X17, 轴距1950, V7G转向) /Front Suspension

序号 No.	零部件图号 Part No.	名称	Part Name	数量 Qty	备注 Remark
1	WG9931524011	前钢板弹簧总成(11片)	Front leaf spring assembly	1	
3	ZQ32720T13F3	凸缘螺母M20*2.5	Nut	8	
4	AZ9003963022	滑脂嘴总成 (CM10*1D71)	Grease nipple	6	
4.1	AZ9003963010	滑脂嘴帽	Grease nipple cap	1	
4.2	1,90004E+11	米制锥螺纹滑脂嘴	Grease nipple	1	
5	WG9100520065	弹簧销	Spring pin	6	
6	1680520050	垫圈	Washer	12	
8	ZQ32516T13F6	六角法兰面带齿螺母M16	Nut	8	
9	ZQ151B1275TF6	六角头螺栓M12*1.25	Bolt	4	
10	ZQ361B12T13F6	2型六角螺母M12*1.25	Nut	6	
11	WG9725520007	前簧前支架	Bracket	2	
12	ZQ1811660TF6	六角法兰面带齿螺栓M16	Bolt	8	
13	WG9731520004	前簧后支架	Bracket	2	
14	ZQ1811675TF6	六角法兰面带齿螺栓M16	Bolt	3	
15	ZQ32516T13F6	六角法兰面带齿螺母M16	Nut	8	
16	AZ9925520016	前簧左前支架	Bracket	1	
17	AZ9731520021	前簧右前支架	Bracket	1	
18	WG9100520034	前簧吊耳总成	Hanger assembly	2	
19	ZQ151B1270TF6	六角头螺栓M12*1.25	Bolt	2	
20	ZQ151B1250	六角头螺栓M12*1.25	Bolt	16	

6.01 HOWO前悬架（8X4, 11X17, 轴距1950, V7G转向）/Front Suspension

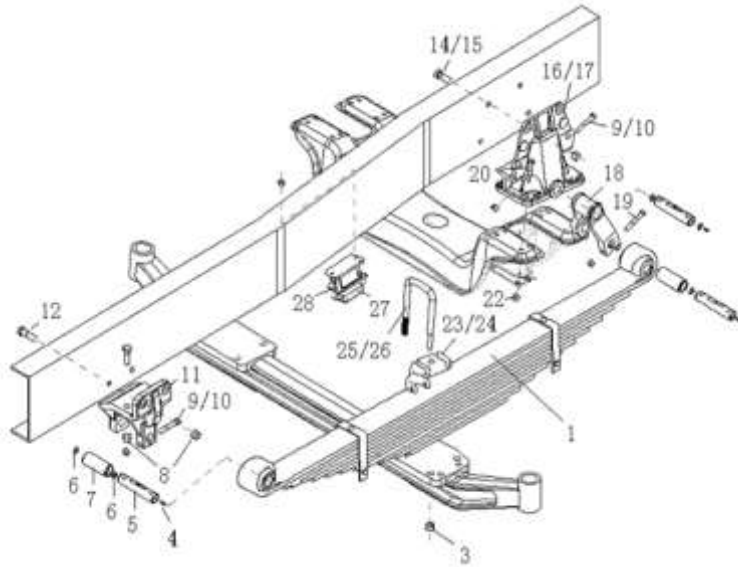

6.01 HOWO前悬架（8X4, 11X17, 轴距1950, V7G转向）/Front Suspension

序号 No.	零部件图号 Part No.	名称	Part Name	数量 Qty	备注 Remark
21	WG9416520030	限位块总成		2	
22	ZQ361B12	2型六角螺母M12*1.25	Nut	16	
23	WG9725520168	前簧压板	Plate	1	
24	WG9725520168	前簧压板	Plate	1	
25	AZ9925520032	前簧骑马螺栓	U-Bolt	2	
26	AZ9925520029	前簧骑马螺栓	U-Bolt	2	
27	WG9323520010	限位块总成	Block assembly	2	
28	WG9731520034	限位支架总成	Bracket assembly	2	
29	ZQ151B1240	六角头螺栓M12*1.25	Bolt	4	
30	ZQ151B1250	六角头螺栓M12*1.25	Bolt	4	
31	ZQ361B12	2型六角螺母M12*1.25	Nut	8	
32	1.99001E+11	弹簧销	Pin	2	
33	ZQ1811675TF6	六角法兰面带齿螺栓M16	Bolt	1	
34	ZQ1811680TF6	六角法兰面带齿螺栓M16	Bolt	1	
35	WG9000520040	弹簧销	Spring pin	4	
36	WG7000520019	定位块	Locating block	6	
37	Q150B1240	六角头螺栓	Screw	8	
38	WG7000520020	止动垫圈	Retainer washer	6	
39	ZQ150B0820	六角头螺栓M8	Bolt	12	
40	AZ9003963032	滑脂嘴总成（CM8*1D714）	Grease nipple	6	

6.02 前桥横向稳定器（1000车架,880板簧距）/Front Stabilizer

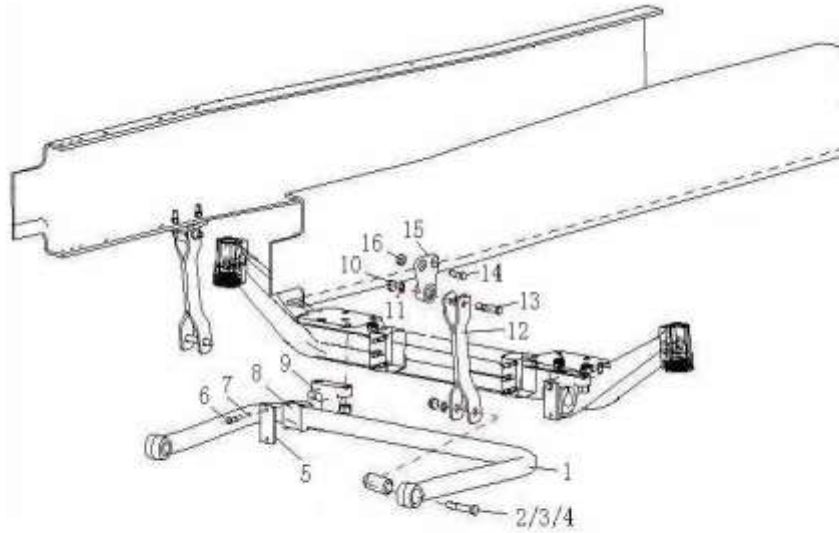

6.02 前桥横向稳定器（1000车架,880板簧距）/Front Stabilizer

序号 No.	零部件图号 Part No.	名称	Part Name	数量 Qty	备注 Remark
1	WG9925680004	前稳定杆总成	Stabilizer bar assembly	1	
2	WG9100680069	螺栓	Bolt	2	
3	Q40214	大垫圈	Washer	2	
4	ZQ32314	六角法兰面螺母M14	Hexagon nuts with flange	2	
5	WG9925680012	垫板	Plate	2	
6	ZQ150B1030TF6	六角头螺栓M10	Bolt	4	
7	Q40310	弹簧垫圈	Spring washer	4	
8	WG9100680068	橡胶轴承	Rubber bearing	2	
9	WG9925680011	固定夹块	Block	2	
10	ZQ361B16	2型六角螺母M16*1.5	Hexagon nuts ,style 2	2	
11	Q40016	小垫圈	Washer	2	
12	WG9160680055	吊板总成	Plate assembly	2	
13	WG9100680057	螺栓	Bolt	2	
14	ZQ151B1240	六角头螺栓M12*1.25	Hexagon head bolts	4	
15	AZ9719680013	稳定杆支架总成	Bracket assembly	2	
16	ZQ361B12	2型六角螺母M12*1.25	Hexagon nuts ,style 2	4	

6.03 HOWO 8×4前减震器/Front Shock Absorber

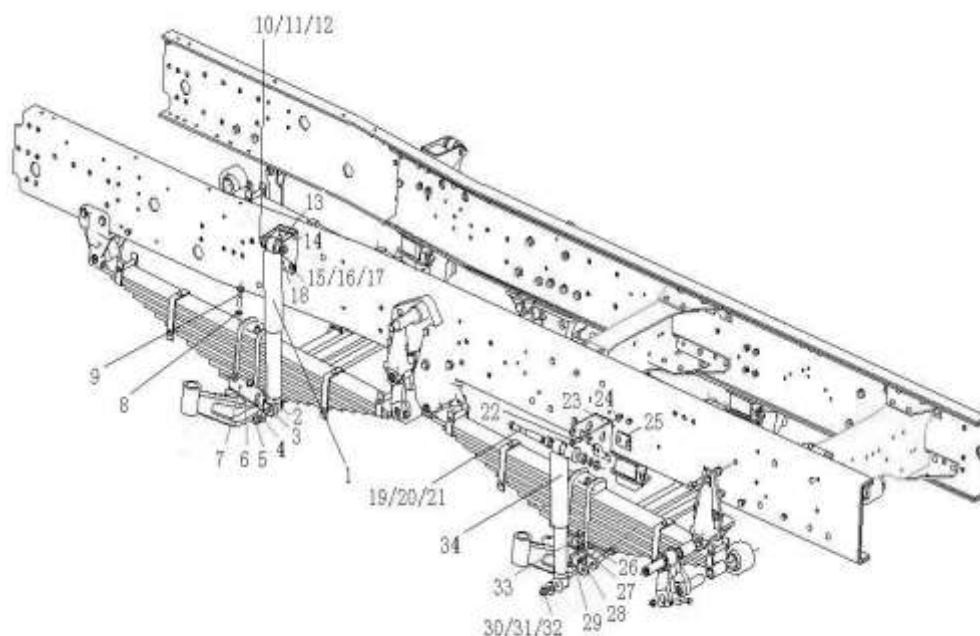

6.03 HOWO 8×4前减震器/Front Shock Absorber

序号 No.	零部件图号 Part No.	名称	Part Name	数量 Qty	备注 Remark
1	WG9725680014	减振器	Shock absorber	2	
2	AZ9003963030	滑脂嘴总成 (AM8*1 D714)	Grease nozzle ass.	2	
3	WG9012680009	螺栓	Screw	2	
4	Q40016	小垫圈	Washer	2	
5	ZQ361B16	2型六角螺母M16*1.5	Nut	2	
6	WG9731680010	垫板	Plate	2	
7	AZ9100680165	减震器下支架分装总成	Lower bracket	2	
8	Q40316	弹簧垫圈	Washer	4	
9	ZQ151B1670	六角头螺栓M16*1.5	Screw	4	
10	WG9100680036	螺栓	Screw	2	
11	Q40016	小垫圈	Washer	2	
12	ZQ361B16	2型六角螺母M16*1.5	Nut	2	
13	WG9731680007	垫板	Plate	2	
14	WG9731680005	减震器上支架总成	Bracket-upper	2	
15	ZQ151B1245	六角头螺栓M12*1.25	Screw	8	
16	Q40112	平垫圈	Washer	1	
17	ZQ361B12	2型六角螺母M12*1.25	Nut	8	
18	WG9100680021	垫板	Plate	2	
19	WG9100680036	螺栓	Screw	2	
20	Q40016	小垫圈	Washer	2	

6.03 HOWO 8×4前减震器/ Front Shock Absorber

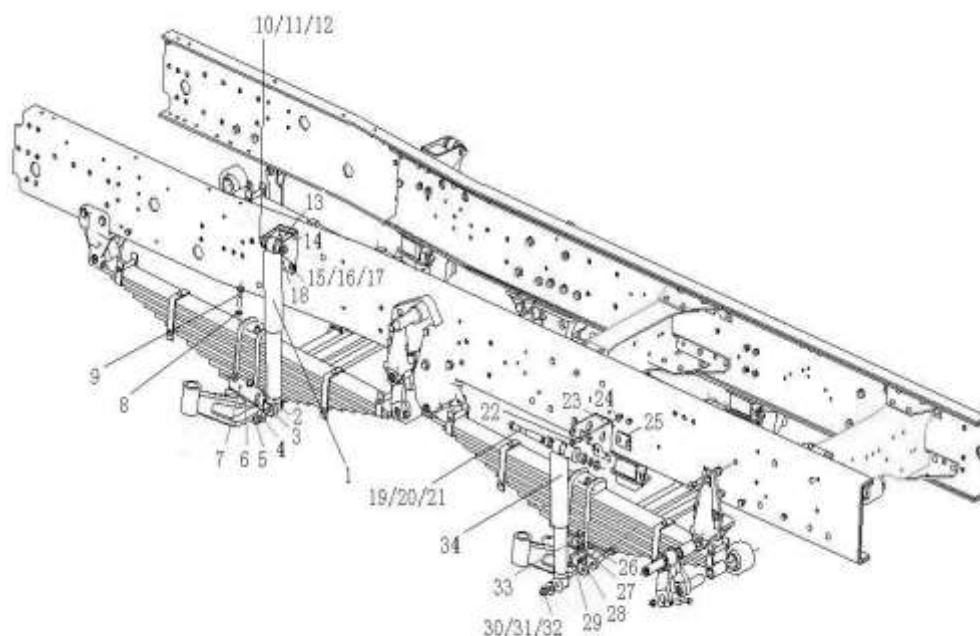

6.03 HOWO 8×4前减震器/ Front Shock Absorber

序号 No.	零部件图号 Part No.	名称	Part Name	数量 Qty	备注 Remark
21	ZQ361B16	2型六角螺母M16*1.5	Nut	2	
22	ZQ151B1245	六角头螺栓M12*1.25	Screw	8	
23	WG9731680016	减震器上支架	Bracket	2	
24	ZQ361B12	2型六角螺母M12*1.25	Nut	8	
25	WG9100680021	垫板	Plate	4	
26	ZQ151B1670	六角头螺栓M16*1.5	Screw	4	
27	Q40316	弹簧垫圈	Washer	4	
28	AZ9003963030	滑脂嘴总成 (AM8*1 D71)	Grease nozzle ass.	2	
29	WG9100680665	减震器下支架分装总成	Lower bracket	2	
30	WG9012680009	螺栓	Screw	2	
31	Q40016	小垫圈	Washer	2	
32	ZQ361B16	2型六角螺母M16*1.5	Nut	2	
33	WG9731680020	垫板	Plate	2	
34	WG9731680031	减震器	Shock absorber	2	
	AZ9118520001	前悬架 (8*4)	Front suspension	1	

6.04 A7后悬架(850、8+8、300高车架、铸造桥、铸造横梁)/Rear Suspension

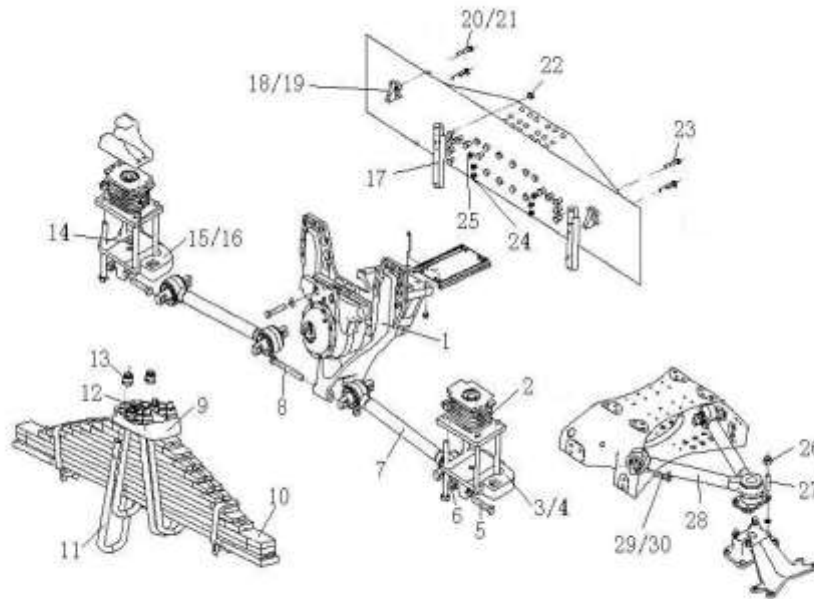

6.04 A7后悬架(850、8+8、300高车架、铸造桥、铸造横梁)/Rear Suspension

序号 No.	零部件图号 Part No.	名称	Part Name	数量 Qty	备注 Remark
1	AZ9925520510	平衡轴带轴壳总成	Balance shaft assembly	2	
1,1	AZ9925520233	支架	Bracket	1	
1,2	AZ9725520237	平衡轴	Balance shaft	1	
1,3	WG9925525235	平衡轴壳	Balance shaft housing	1	
1,4	WG9925520062	密封圈	Sealingring	1	
1,5	WG9114520042	球面轴承	Spherical bearing	2	
1,6	WG9725520136	轴承油封盖	Oil sealing cover	1	
1,7	WG614130062	密封圈	Sealingring	1	
1,8	WG9114520223	轴密封圈	Sealing ring	2	
1,9	WG9725520238	间隔衬套	Spacing bush	1	
1,1	WG9014520192	定位垫圈	Fix washer	1	
1,11	WG9014520193	定位垫圈	Fix washer	1	
1,12	WG9014520194	定位垫圈	Fix washer	1	
1,13	WG9014520303	定位垫圈	Fix washer	1	
1,14	WG9014520306	定位垫圈	Fix washer	1	
1,15	WG9114520059	定位垫圈	Fix washer	1	
1,16	WG9100520008	定位垫圈	Fix washer	1	
1,17	WG9725520239	轴承压块	Pad	1	
1,18	Q150B0810	六角头螺栓	Screw	1	
1,19	Q72308T5F	密封垫圈	Sealing	1	

6.04 A7后悬架(850、8+8、300高车架、铸造桥、铸造横梁)/Rear Suspension

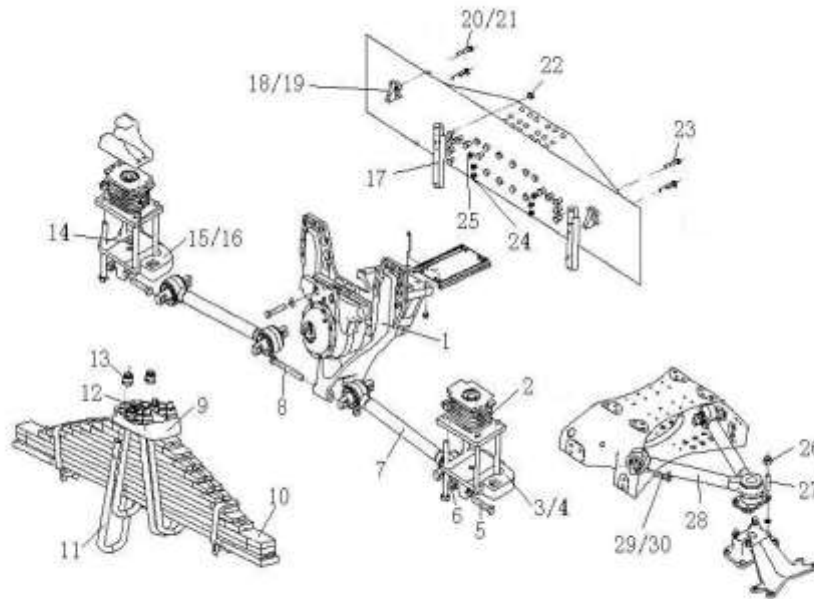

6.04 A7后悬架(850、8+8、300高车架、铸造桥、铸造横梁)/Rear Suspension

序号 No.	零部件图号 Part No.	名称	Part Name	数量 Qty	备注 Remark
1,2	Q150B1445TF2	六角头螺栓	Screw	6	
1,21	Q40314	弹簧垫圈	Springwasher	6	
1,22	WG9014520311	壳盖	Cover	1	
1,23	1,90004E+11	锥螺纹内六角螺塞	Screw plug	1	
1,24	Q150B0820	六角头螺栓	Screw	8	
1,25	Q40308	弹簧垫圈	Springwasher	8	
1,26	Q5211630	园柱销	Pin	1	
2	AZ9925525286	橡胶支座总成	Rubber base assembly	4	
3	WG9725520194	推力杆后左支架	Bracket	1	
4	WG9725520195	推力杆后右支架	Bracket	1	
5	ZQ151B20100TF	六角头螺栓M20*1.5	Hexagon head bolts	8	
6	ZQ361B20T13F6	2型六角螺母M20*1.5	Hexagon nuts ,style 2	12	
7	AZ9631523175	浇铸式推力杆总成	Rod assembly	4	
7,1	AZ9631521177	球面销总成	Pin	2	
7,2	WG9631520044	直球座	Seat	2	
7,3	WG9631524209	挡圈	Ring	2	
7,4	AZ9114521186	连接杆	Rod	1	
8	ZQ151B20180TF	六角头螺栓M20*1.5	Hexagon head bolts	4	
9	AZ9925520366	板簧压块	Block	2	
10	WG9725520389	后钢板弹簧总成	Rear leaf spring	2	

6.04 A7后悬架(850、8+8、300高车架、铸造桥、铸造横梁)/Rear Suspension

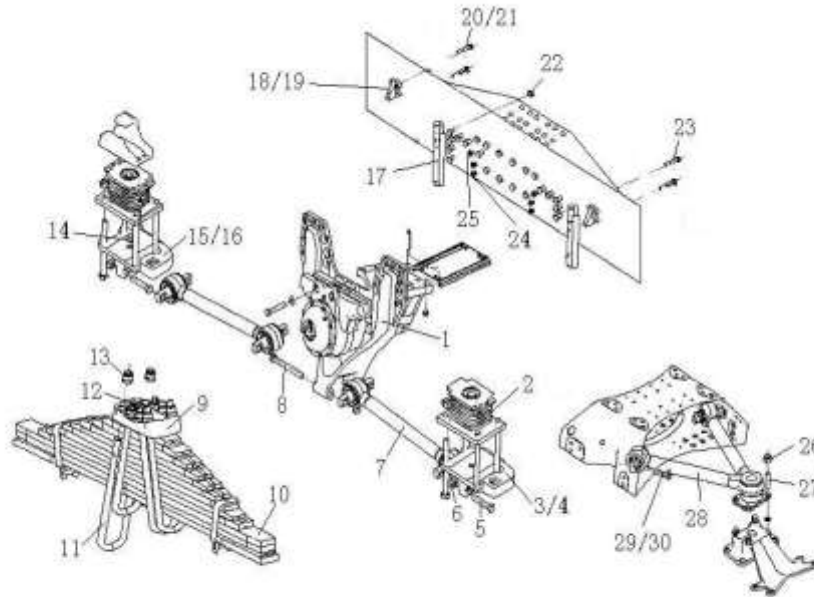

6.04 A7后悬架(850、8+8、300高车架、铸造桥、铸造横梁)/Rear Suspension

序号 No.	零部件图号 Part No.	名称	Part Name	数量 Qty	备注 Remark
10.1	WG9725520389+	后钢板弹簧总成(共12片)	1st piece of rear spring	1	
10.10	WG9725520389+	后钢板弹簧总成(共12片)	10th piece of rear spring	1	
10.11	WG9725520389+	后钢板弹簧总成(共12片)	11th piece of rear spring	1	
10.12	WG9725520389+	后钢板弹簧总成(共12片)	12th piece of rear spring	1	
10.13	WG9725520389+	中心螺栓	Central screw	1	
10.14	WG9725520389+	中心螺母	Central nut	1	
10.2	WG9725520389+	后钢板弹簧总成(共12片)	2nd piece of rear spring	1	
10.3	WG9725520389+	后钢板弹簧总成(共12片)	3rd piece of rear spring	1	
10.4	WG9725520389+	后钢板弹簧总成(共12片)	4th piece of rear spring	1	
10.5	WG9725520389+	后钢板弹簧总成(共12片)	5th piece of rear spring	1	
10.6	WG9725520389+	后钢板弹簧总成(共12片)	6th piece of rear spring	1	
10.7	WG9725520389+	后钢板弹簧总成(共12片)	7th piece of rear spring	1	
10.8	WG9725520389+	后钢板弹簧总成(共12片)	8th piece of rear spring	1	
10.9	WG9725520389+	后钢板弹簧总成(共12片)	9th piece of rear spring	1	
11	AZ9925520268	后簧骑马螺栓	U-bolt	4	
12	WG9000520006	导向销	Pin	4	
13	ZQ32724T13F3	凸缘螺母M24*3	Nut	16	
14	190003901905	园柱销--销GB119 A20*24	Pin	4	
15	WG9725520290	推力杆前左支架	Bracket	1	
16	WG9725520291	推力杆前右支架	Bracket	1	

6.04 A7后悬架(850、8+8、300高车架、铸造桥、铸造横梁)/Rear Suspension

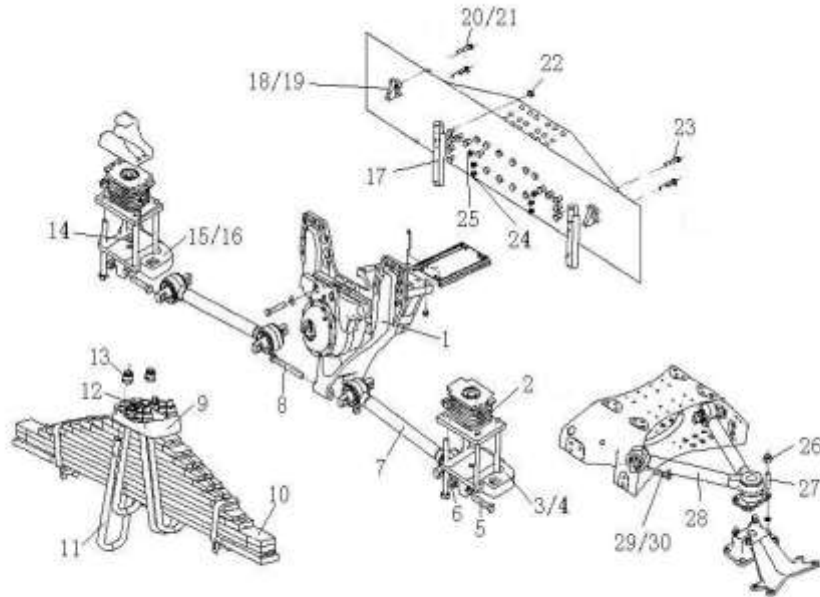

6.04 A7后悬架(850、8+8、300高车架、铸造桥、铸造横梁)/Rear Suspension

序号 No.	零部件图号 Part No.	名称	Part Name	数量 Qty	备注 Remark
17	WG9725522250	导向板	Guide plate	4	
18	WG9725520728	限位支架	Bracket	4	
19	WG9725520727	限位块总成	Block assembly	4	
20	ZQ151B1470	六角头螺栓M14*1.5	Bolt	6	
21	ZQ151B1460	六角头螺栓M14*1.5	Bolt	2	
22	ZQ361B14	2型六角螺母M14*1.5	Nut	8	
23	Q150B1260	六角头螺栓	Screw	16	
24	WG9925521014	内六角沉头螺钉	Hexagon Socket Countersu	8	
25	WG9925521007	内六角沉头螺钉	Hexagon Socket Countersu	4	
26	ZQ32318T13F6	六角法兰面螺母M18*1.5	Hexagon nuts with flange	8	
27	WG9725520228	双头螺柱	Stud	8	
28	AZ9725529272	V型推力杆总成	Rod assembly	2	
28,1	WG9725526205	关节轴承总成	Bearing	1	
28,2	AZ9725527211	连接杆	Rod	2	
28,3	WG9725527203	卡簧	Spring	1	
28,4	WG9725528212	直球座	Seat	2	
28,5	WG9725529209	直球座挡圈	Ring	2	
28,6	WG9725529214	内密封圈	Ring	2	
28,7	WG9725529215	外密封圈	Ring	2	
28,8	WG9725527204	护套	Sleeve	1	

6.04 A7后悬架(850、8+8、300高车架、铸造桥、铸造横梁)/Rear Suspension

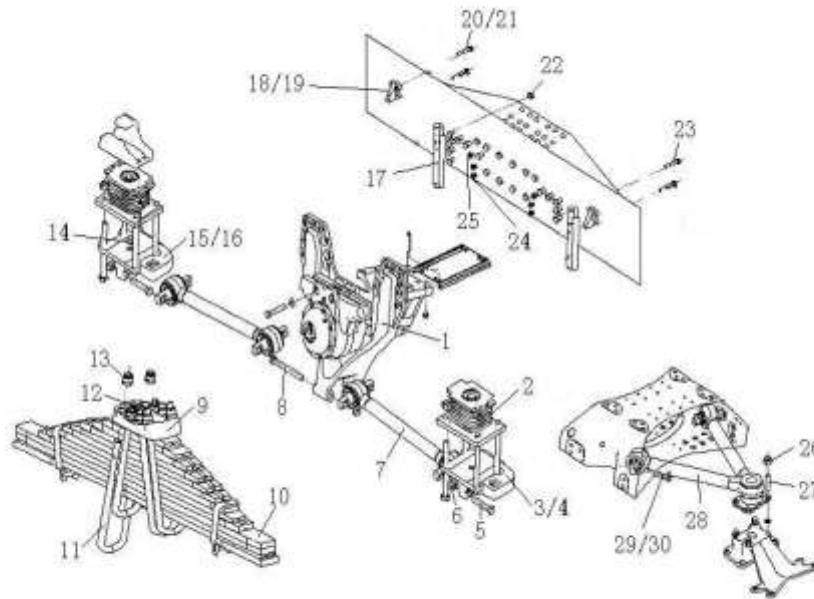

6.04 A7后悬架(850、8+8、300高车架、铸造桥、铸造横梁)/Rear Suspension

序号 No.	零部件图号 Part No.	名称	Part Name	数量 Qty	备注 Remark
28,9	WG9725527215	喉箍总成	Clamp	1	
28,1	WG9725527209	上球座挡圈	Ring	1	
28,11	WG9725529213	球面销总成	Pin	2	
28,12	AZ9725526201	上球座	Seat	1	
28,13	AZ9725527202	推力杆安装座	Install seat	1	
28,14	WG9725527230	上端盖总成	Cover	1	
28,15	ZQ1851850TF6	六角法兰面螺栓M18*1.5	Hexagon bolts with flange	1	
29	WG9725520367	防松套	Sleeve	8	
30	WG9725520114	V型推力杆螺栓	Bolt of V rod	8	
31	ZQ1811670TF6	六角法兰面带齿螺栓M16	Bolt	24	
32	ZQ1811675TF6	六角法兰面带齿螺栓M16	Bolt	2	
33	ZQ361B16T13F6	2型六角螺母M16*1.5	Hexagon nuts ,style 2	4	
34	ZQ32516T13F6	六角法兰面带齿螺母M16	Nut	34	
35	ZQ1811680TF6	六角法兰面带齿螺栓M16	Bolt	16	
36	ZQ32516T13F6	六角法兰面带齿螺母M16	Nut	16	
37	AZ9125520268	后簧骑马螺栓	Rear spring clip	4	
38	ZQ340B10	1型六角螺母M10*1.5	Hexagon nuts ,style 1	16	
39	WG9925525283	左前支架	Bracket	2	
40	WG9925525285	右前支架	Bracket	2	
41	Q218B1435	内六角圆柱头螺钉	Screw	16	

6.05 搅拌车后横向稳定器（850车架, 标准孔）/Stabilizer

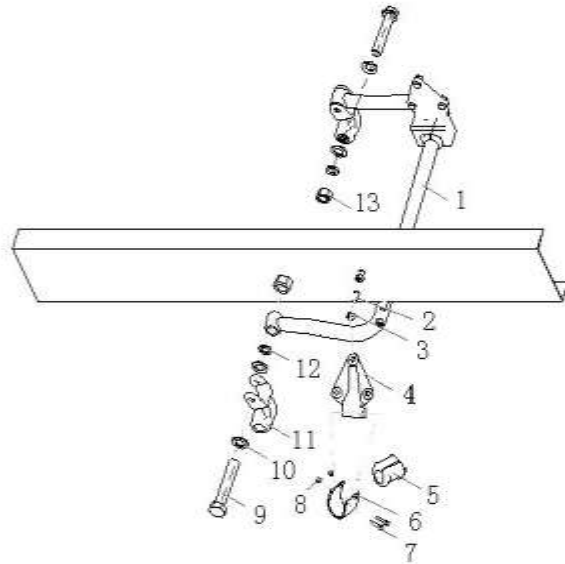

6.05 搅拌车后横向稳定器（850车架, 标准孔）/Stabilizer

序号 No.	零部件图号 Part No.	名称	Part Name	数量 Qty	备注 Remark
1	WG9719680006	后稳定杆总成	Stabilizer bar assembly	1	
2	WG9719680039	螺栓	Hexagon head bolts	6	
3	ZQ361B16	2型六角螺母M16*1.5	Hexagon nuts ,style 2	6	
4	WG9719680058	稳定杆托架(标准孔)	Bracket	2	
5	WG9100680067	橡胶轴承	Rubber bearing	2	
6	WG9719680032	轴承夹	Bearing clip	2	
7	ZQ151B1295	六角头螺栓M12*1.25	Hexagon head bolts	4	
8	ZQ361B12	2型六角螺母M12*1.25	Hexagon nuts ,style 2	4	
9	WG9719680049	螺栓	Bolt	4	
10	1780680030	垫圈	Washer	4	
11	WG9719680060	平衡夹总成	Circlip assembly	2	
12	Q40016	小垫圈	Washer	4	
13	ZQ361B16	2型六角螺母M16*1.5	Hexagon nuts ,style 2	4	
14	ZQ1811445TF6	六角法兰面带齿螺栓M14	Bolt	2	
15	ZQ1811450TF6	六角法兰面带齿螺栓M14	Bolt	2	
16	ZQ32514T13F6	六角法兰面带齿螺母M14	Nut	2	